

Check of input signal system

Throttle sensor system (with self diagnostic 43 indications)

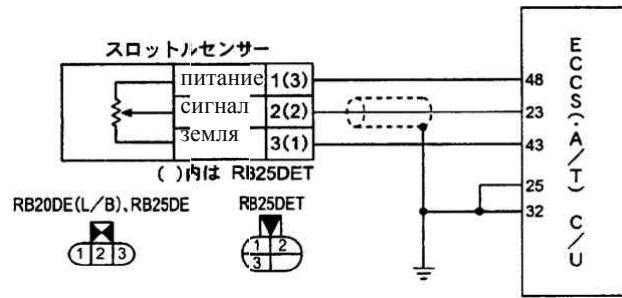

RB20DE (L/B)、RB25DE

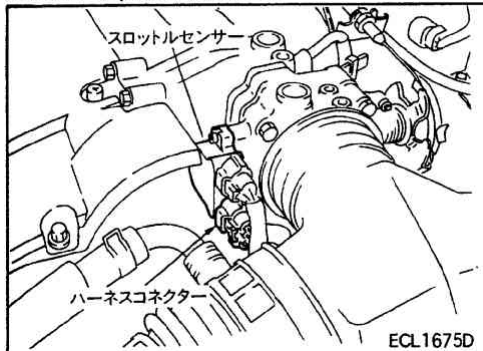

Inspection of input signal

・ファンクションテストの"スロットルセンザ又は作業サポー не перевелось"

The voltage is checked by "Throttle sensor adjustment"

- ・ The key switch is turned on.
 - ・ check the voltage between earth and pin C / U 23.
- At the time of accelerator full closing: Approximately 0.5V
 At the time of accelerator full opening: Approximately 4.2V

Note: When keeping stepping on the accelerator pedal slowly from the full closing, being proportionate to accelerator opening, voltage rises.

RB25DET

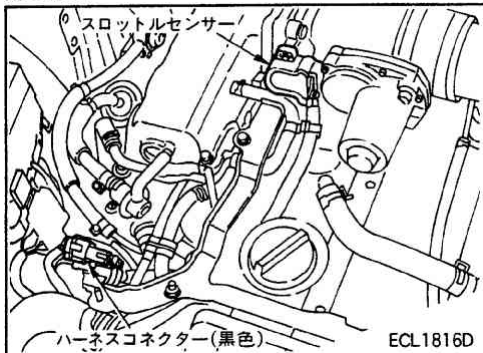

In case of NG, description below is inspected.

- ・ Power circuit, input signal circuit and ground circuit
- ・ Damage of C/U terminal or engagement of each connector

Inspection of component

Throttle Sensor

Check the resistance between terminals • Left figure.

(At the normal temperature)

At the time of accelerator full closing: Approximately 0.6~1kΩ
 At the time of accelerator full opening: Approximately 4~4.3kΩ
 (Resistance increases with increased amount of foot)

Attention: Delete the self-diagnosis result of each C/U when you remove the harness connector of the throttle sensor in key switch ON or the engine rotation. "Air/fuel ratio check at idle rotational speed and ignition timing" EC- 40-page reference

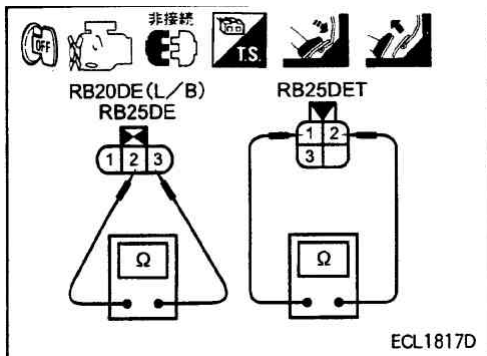

Input signal inspection system

RB20DE(L/B),RB25DE

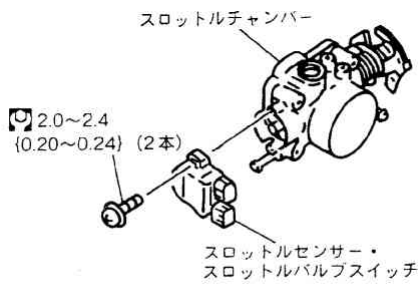

□ : N-m {kg-m}

EML1958D

RB20DE(L/B),RB25DE

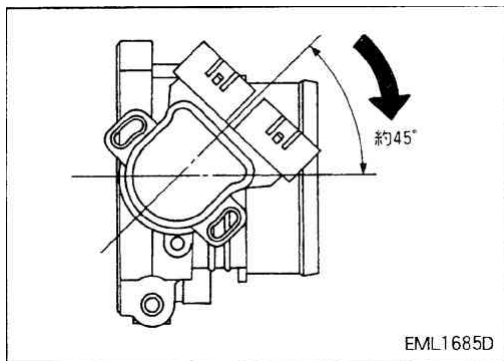

RB25DET

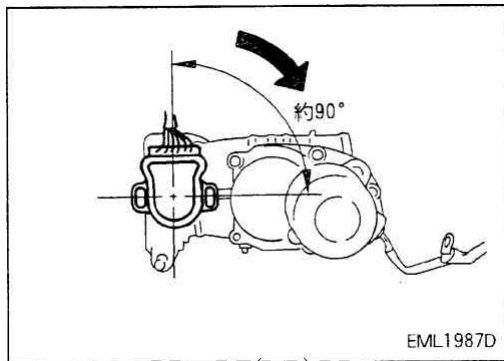

RB20DE(L/B),RB25DE

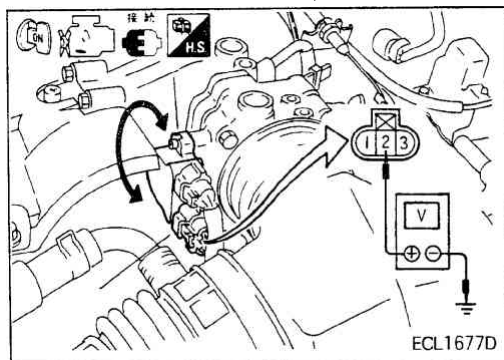

RB25DET

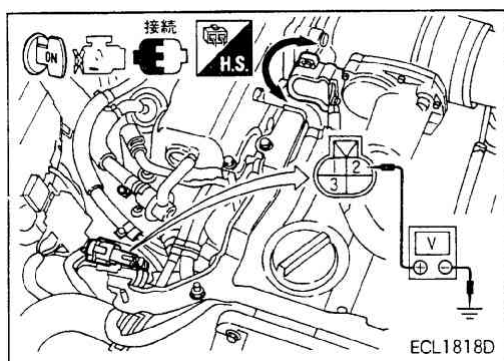

Throttle sensor system (with self diagnostic 43 indications)
(continuation) removal and re-installation of component
throttle position sensor [M / T]
Throttle valve throttle sensor switch [A / T]

Removal and re-installation main point also M/T and A/T removes the similar

1. engine cover.
2. The harness connector is removed, and throttle sensor throttle bus Remove the valve switch.

Attention point when installing

In order connector for direction to become the left figure direction, it inserts in the throttle chamber, turns clockwise and tightens temporarily with the installation screw.

After the adjusting below, the installation screw is tightened by stipulated torque.

The adjustment

1. throttle sensor after the tightening temporarily, the harness connector is connected and the engine is warmed up.
2. With key ON (engine stop) it puts in state, in order for the throttle sensor output voltage which is during 2nd terminal ~ body grounding of the throttle sensor to become $0.5 \pm 0.05V$, moving the throttle sensor, it adjusts.
3. The throttle sensor installation screw is tightened securely.
4. For the second time, output voltage of the throttle sensor is verified.
5. Using consultation, " of the data monitor; [aidoruhantei]" with you verify that idling decision becomes ON. Idling decision has become OFF, (engine rpm it is high) when, until idling decision becomes ON, ON<->OFF operation of key ON is repeated at approximately 2 ~3 second interval. (Standard of frequency of ON<->OFF operation: 3~10 time)
6. The engine is started, idle based rpm is adjusted reference level. "Idle rpm, ignition timing, inspection of air fuel ratio)" EC-39 page reference M/T cancels closed-loop control stop. A/T continues the job below.

Check of input signal system

RB20DE(L/B),RB25DE

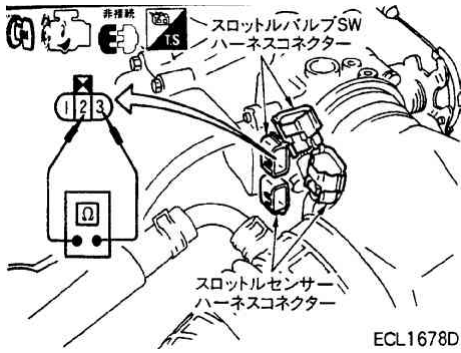

The throttle sensor system (43 displays by the self-diagnosis)(continuation).

7. The harness connector of the throttle valve switch is removed when closed-loop control of idle rpm is stopped, 2nd ~3 turn when idling (RB25DET when 1st ~3 turn) resistance between the terminals increased 0Ω and engine rpm, verifies that resistance is $\infty\Omega$.

Note: When idling when the idle contact point becomes OFF, (2nd ~3 turn (RB25DET 1st ~3 turn) resistance between the terminals $\infty\Omega$.

You adjust the throttle sensor 2nd ~3 turn (1st ~3 turn) resistance between the terminals try RB25DET that it becomes for the second time, 0Ω .

This time, also the fact that it comes off from $0.5\pm 0.05V$ there is a throttle sensor output voltage, but it does not care.

When idling the fact that the idle contact point of the throttle valve switch is ON is preferred.

Рисунок сверху, перевод с японского:
Верхний разъем – Throttle valve SW.
Harness connector.
Нижний разъем - Throttle sensor.
Harness connector.

RB25DET

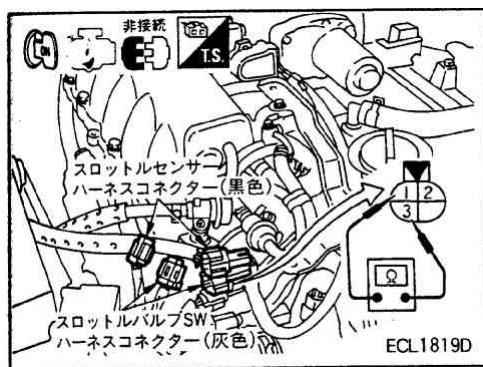

8. Next accelerator " Resetting the accelerator from opening" state gradually, it keeps reducing engine rpm, $900\pm 150\text{rpm}$ (2nd ~3 turn (as for RB25DET 1st ~3 turn) resistance between the terminals 0Ω) verifies that it becomes at touch rpm of the idle contact point.

Note: There are also times when touch rpm comes off from $900\pm 150\text{rpm}$.

9. The feedback control stop is released.

Attention: Delete the self-diagnosis result of each C/U.

Refer to "Air/fuel ratio check at the idol rotational speed and the ignition timing" EC-40 page.